



The information in this document is subject to change without notice and should not be construed as a commitment by ABB. ABB assumes no responsibility for any errors that may appear in this document.

Except as may be expressly stated anywhere in this document, nothing herein shall be construed as any kind of guarantee or warranty by ABB for losses, damages to persons or property, fitness for a specific purpose or the like.

In no event shall ABB be liable for incidental or consequential damages arising from use of this document.

This document and parts thereof must not be reproduced or copied without ABB's written permission, and contents thereof must not be imparted to a third party nor be used for any unauthorized purpose. Contravention will be prosecuted.

Additional copies of this document may be obtained from ABB at its then current charge.

© Copyright 2023 ABB ALL right reserved.

ABB Engineering (Shanghai) Ltd
No.4528, Kangxin Highway,Kangqiao Town
Pudong New District, Shanghai, 201319
P.R.China

Latest revision:			Lab/Office: RA/RDP	IRB1090 COPYRIGHT PAGE	Status: Approved	Plant: = Location: + Sublocation: +
					Document no. 3HAC085352-007	Rev. Ind 00
Prepared by, date: CNPAXU1	Approved by, date: CNKEWAN10					



Description : IRB1090
 Drawing number : 3HAC085352-007
 Drawing version : 00
 Date :

Customer :
 Year of construction :
 :
 :
 :
 :
 :
 :
 :

Drawn by : CNPAXU1
 Number of pages : 17
 :
 :
 :
 :

Latest revision:			Lab/Office: RA/RDP	IRB1090 TITLE PAGE	Status: Approved	Plant: = Location: + Sublocation: +	Document no. 3HAC085352-007	Rev. Ind 00	Page 2 Next 3 Total 17
			Prepared by, date: CNPAXU1		Approved by, date: CNKEWAN10				

We reserve all rights in this document. No part of this document may be reproduced, stored in a retrieval system, or transmitted in any form or by any means, electronic, mechanical, photocopying, recording, or by any information storage and retrieval system, without express authority in writing from ABB. © Copyright 2002 ABB

Valid for:

This circuit diagram is valid for the following cable harness & board unit assemblies:

Harness for Robot:

3HAC060420-001 L Basic
 3HAC060420-002 L Basic+CP/CS+4x4mm air hose
 3HAC060420-003 L Basic+CP/CS+4x4mm air hose+Eth.

3HAC060416-001 U Basic Ext.
 3HAC060416-002 U Basic+CPCS+4x4mm air Ext.
 3HAC060416-003 U Basic+CPCS+4x4mm air+Eth.Ext.

3HAC060418-001 Process hub Basic
 3HAC060418-003 Process hub CPCS+4x4mm air
 3HAC060418-005 Process hub CPCS+4x4mm air+Eth.

Board unit for Robot:

3HAC063968-001 SMB Unit
 3HAC044075-001 Battery Unit

Latest revision:



Lab/Office:
RA/RDP

IRB1090
VALID FOR

Status:

Approved

Plant: =

Location: +

Sublocation: +

Document no.

3HAC085352-007

Rev. Ind

00

Page 8

Next 9

Total 17

Prepared by, date: CNPAXU1

Approved by, date: CNKEWAN10

2023-03-30 First version Ver00

We reserve all rights in this document, and in the information contained therein, and in the reproduction, distribution or disclosure to third parties without express authority is strictly forbidden. © Copyright 2002 ABB

Latest revision:	
Prepared by, date: CNPAXU1	Approved by, date: CNKEWAN10



Lab/Office: RA/RDP

IRB1090
REVISION INFORMATION

Status: Approved	Plant: = Location: + Sublocation: +	Rev. Ind 00	Page 9 Next 10 Total 17
Document no. 3HAC085352-007			

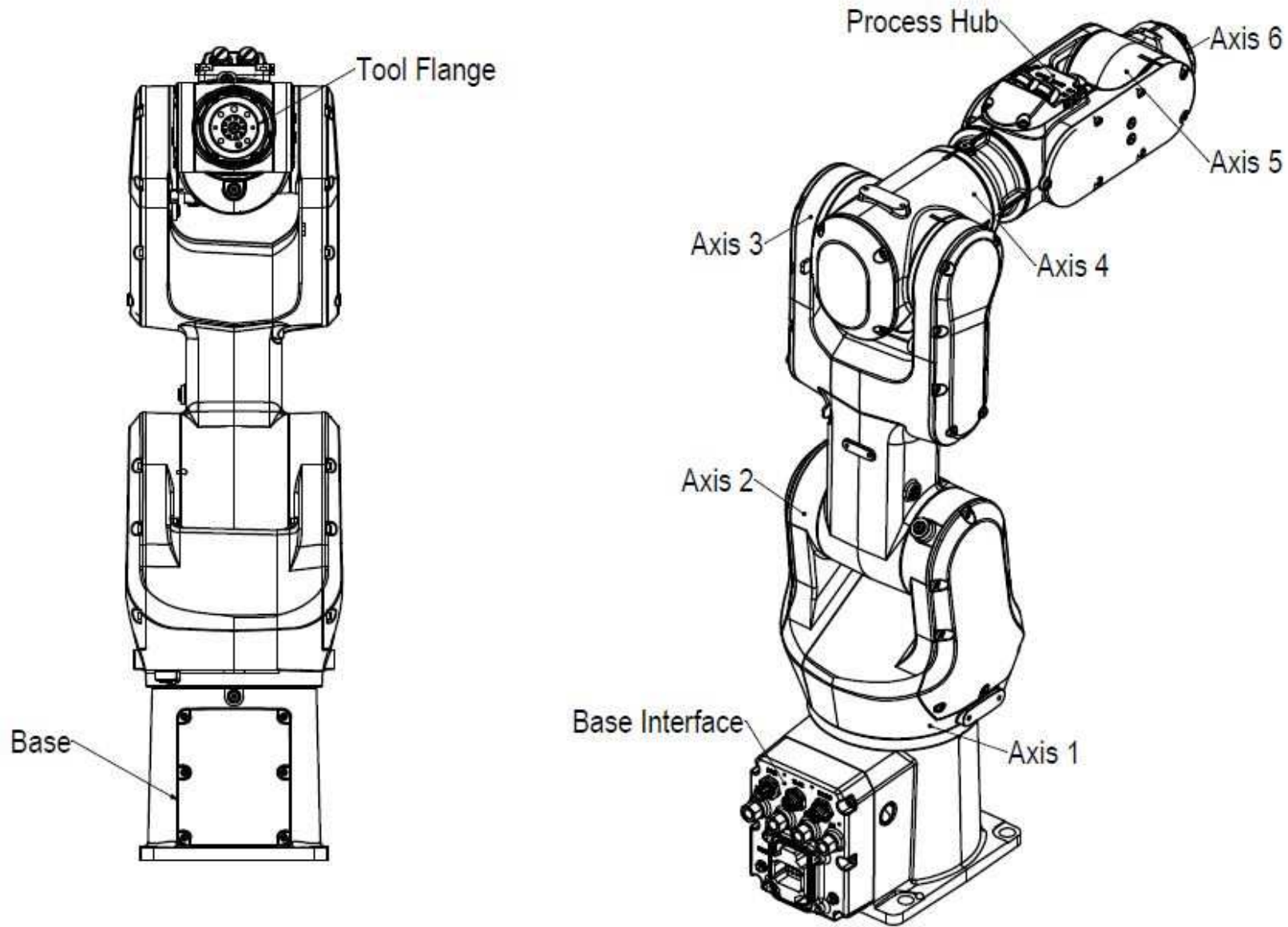

We reserve all rights in this document, and in the information contained herein, to ABB. All rights reserved. No part of this document may be reproduced, stored in a retrieval system, or transmitted in any form or by any means, electronic, mechanical, photocopying, recording, or by any information storage and retrieval system, without express authority in writing from ABB. © Copyright 2002 ABB

Latest revision:

Prepared by, date: CNPAXU1 | Approved by, date: CNKEWAN10

ABB Lab/Office: RA/RDP

IRB1090
SYSTEM OVERVIEW

Status: Approved	Plant: Location: Sublocation: = + +	Rev. Ind 00	Page 10 Next 11 Total 17
Document no. 3HAC085352-007			

R2.C2(option)
 R2.C1(option)
 A3.A4 (option)
 A1.A2 (option)

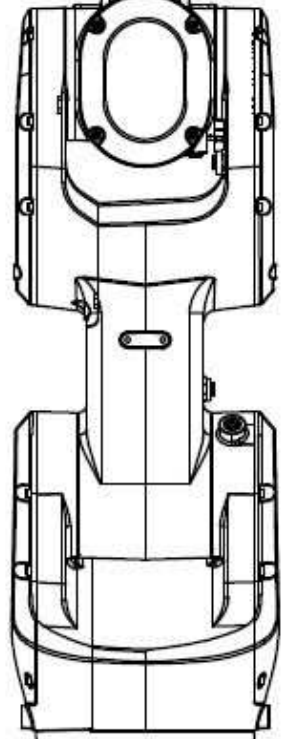

R1.C2(option)
 R1.C1(option)
 A1(option)
 A2(option)
 R1.MP
 R1.SMB
 A4(option)
 A3(option)

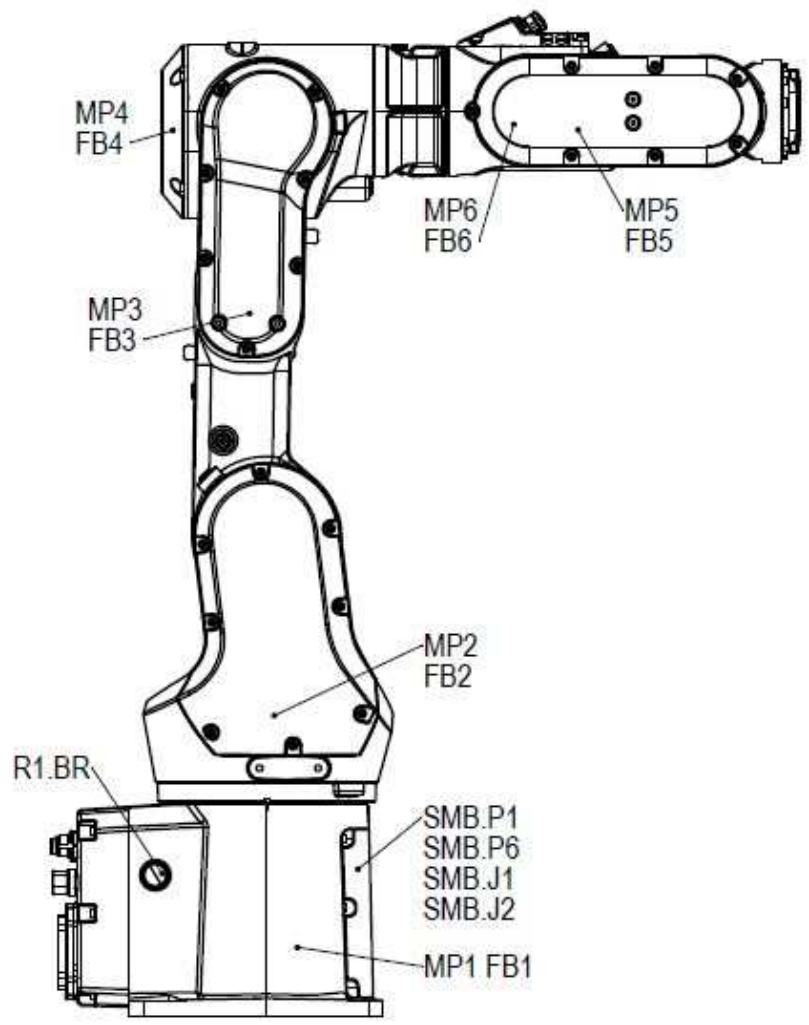

MP4
 FB4
 MP6
 FB6
 MP5
 FB5
 MP3
 FB3
 MP2
 FB2
 R1.BR
 SMB.P1
 SMB.P6
 SMB.J1
 SMB.J2
 MP1
 FB1

We reserve all rights in this document. Any information contained herein is confidential and its disclosure to third parties without express authority is strictly forbidden. © Copyright 2002 ABB

Latest revision:

Prepared by, date: CNPAXU1 | Approved by, date: CNKEWAN10

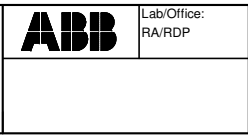

Lab/Office:
 RA/RDP

IRB1090
 CONNECTION POINT LOCATION

Status: Approved	Plant: Location: Sublocation:	= + +
Document no. 3HAC085352-007	Rev. Ind 00	Page 11 Next 15 Total 17

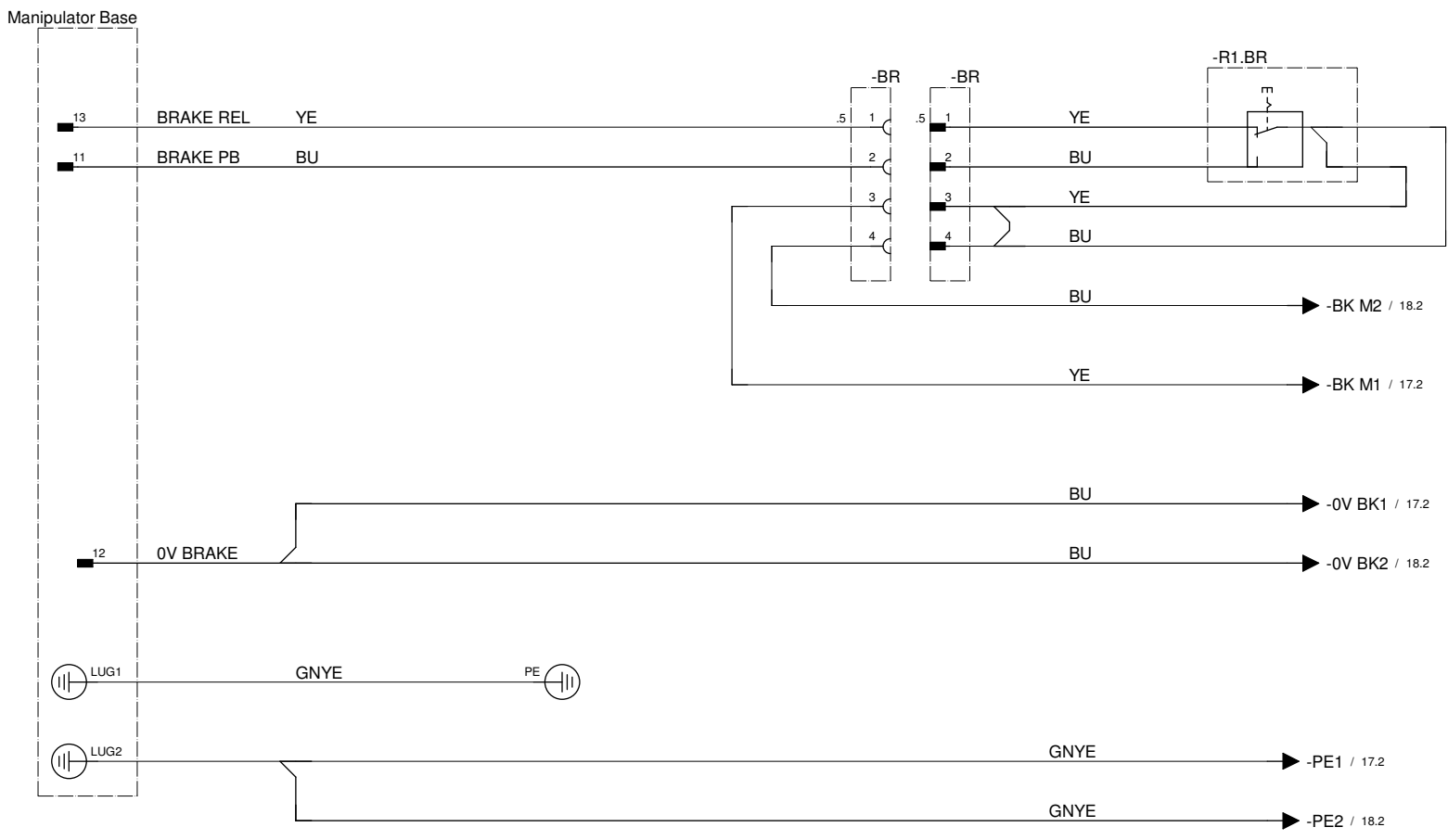

We reserve all rights in this document. No part of this document may be reproduced, stored in a retrieval system, or transmitted in any form or by any means, electronic, mechanical, photocopying, recording, or by any information storage and retrieval system, without express authority in writing from ABB. © Copyright 2002 ABB

Latest revision:

Prepared by, date: CNPAXU1 | Approved by, date: CNKEWAN10



Lab/Office:
RA/RDP

IRB1090
BRAKE RELEASE UNIT

Status:
Approved

Plant: =
Location: +
Sublocation: +

Document no.
3HAC085352-007

Rev. Ind	Page 15
00	Next 16
	Total 17

Manipulator Base

-R1.SMB

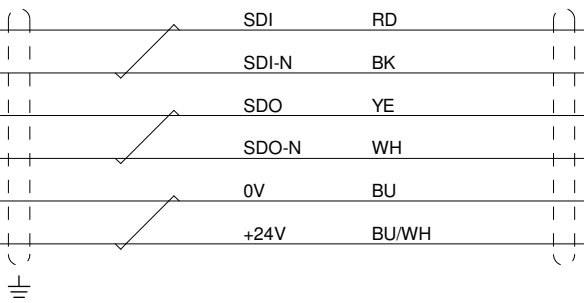

-SMB

-SMB.P6

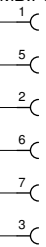

-SMB.P1

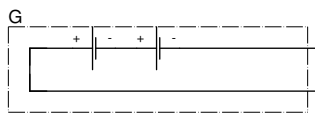
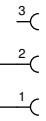

Latest revision:
Prepared by, date: CNPAXU1 | Approved by, date: CNKEWAN10



Lab/Office:
RA/RDP

IRB1090
SERIAL MEASUREMENT BOARD

Status:
Approved

Plant: =
Location: +
Sublocation: +

Document no.
3HAC085352-007

Rev. Ind	Page 16
00	Next 17
	Total 17

We reserve all rights in this document, and no part of this document may be reproduced, stored in a retrieval system, or transmitted in any form or by any means, electronic, mechanical, photocopying, recording, or by any information storage and retrieval system, without express authority in writing from ABB. © Copyright 2002 ABB

Manipulator Base

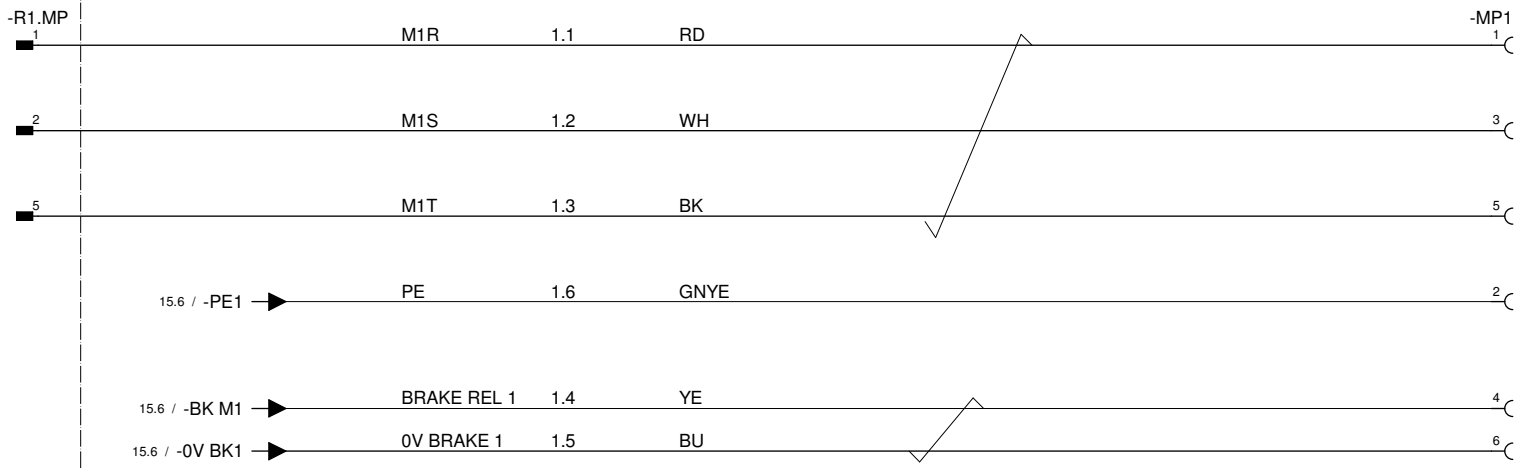

-M1

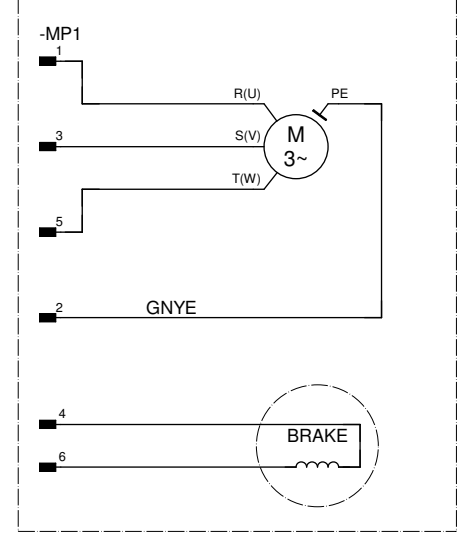

-SMB

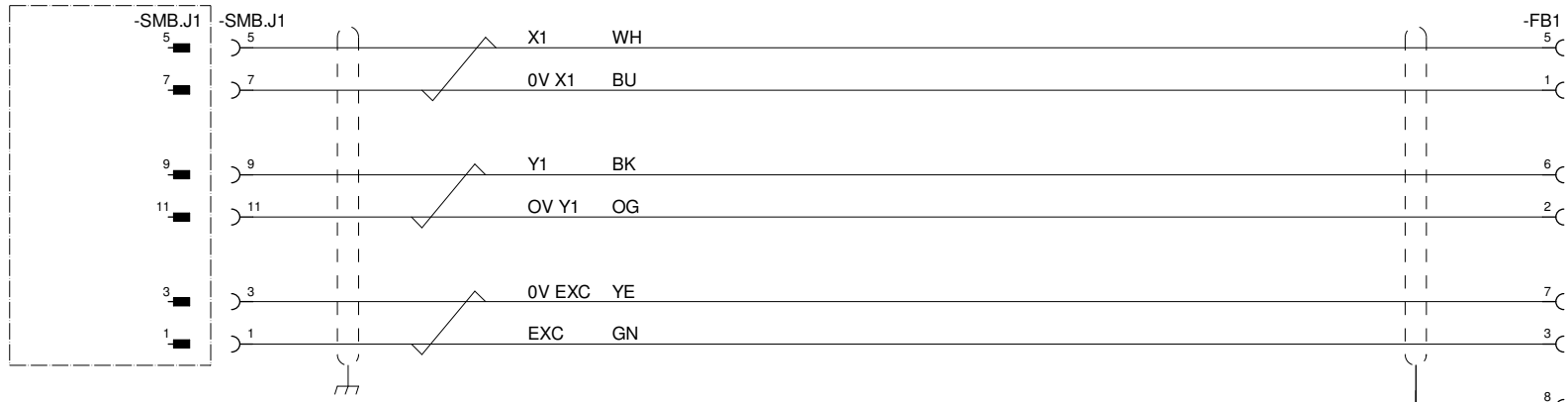

-FB1

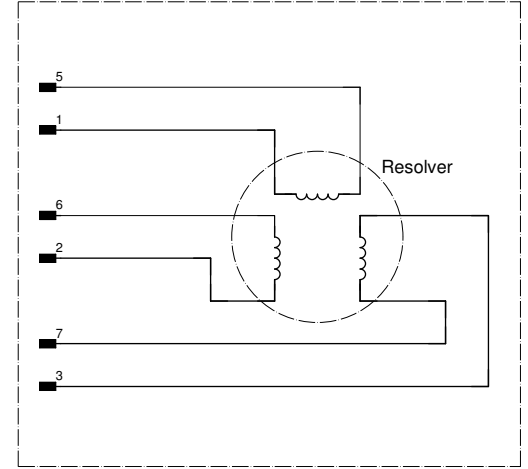

Latest revision:
Prepared by, date: CNPAXU1 | Approved by, date: CNKEWAN10

ABB Lab/Office: RA/RDP
IRB1090
AXIS 1

Status: Approved	Plant: = Location: + Sublocation: +
Document no. 3HAC085352-007	Rev. Ind 00
	Page 17 Next 18 Total 17

We reserve all rights in this document. No part of this document may be reproduced, stored in a retrieval system, or transmitted in any form or by any means, electronic, mechanical, photocopying, recording, or by any information storage and retrieval system, without express written permission from ABB. © Copyright 2002 ABB

Manipulator Base

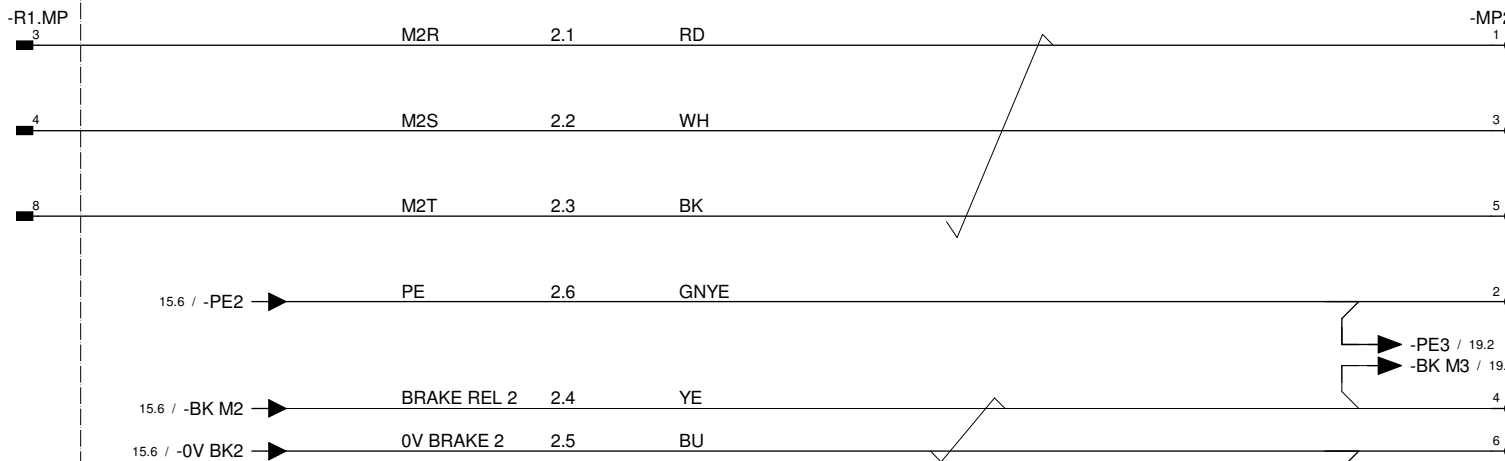

-M2

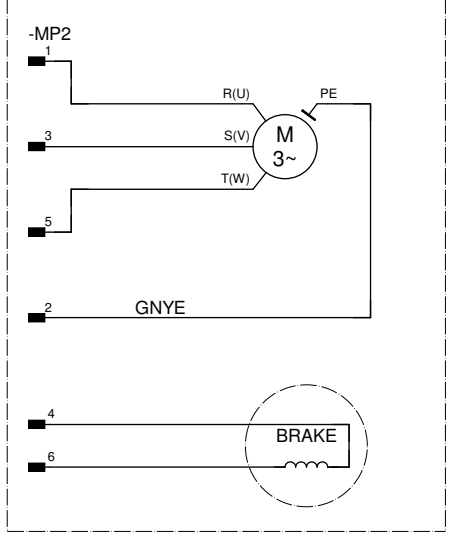

-SMB

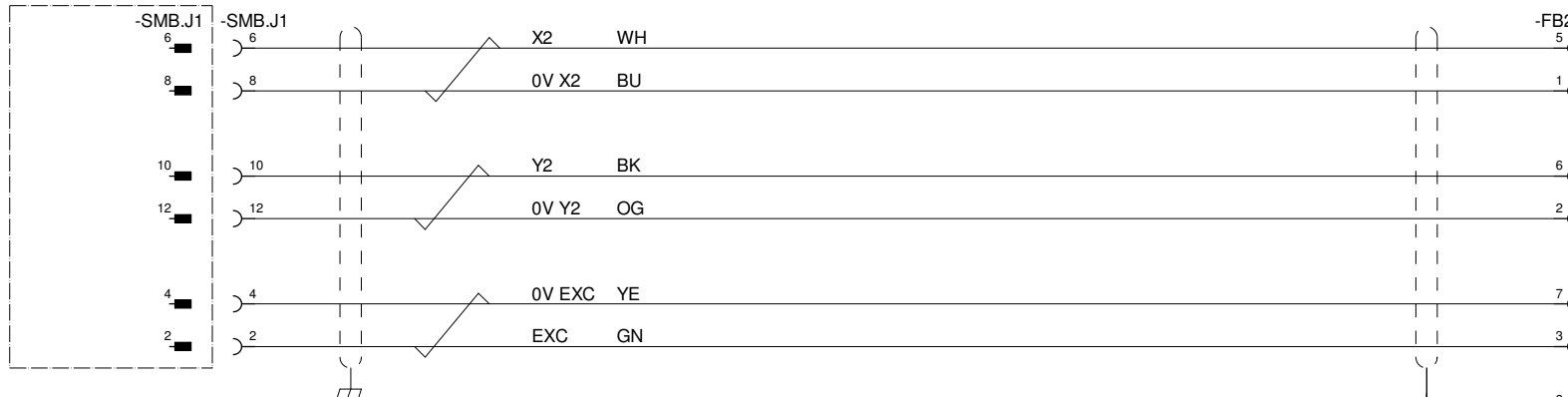

-FB2

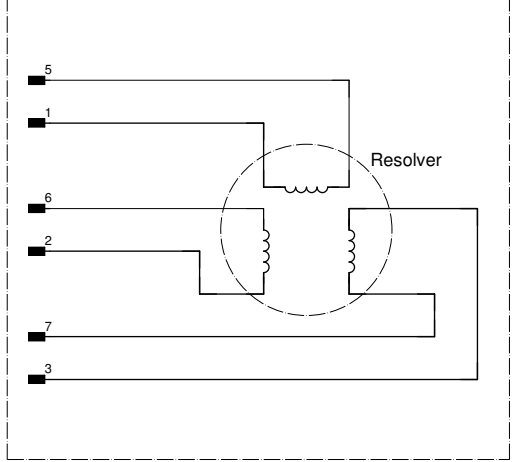

Latest revision:
Prepared by, date: CNPAXU1 | Approved by, date: CNKEWAN10

ABB Lab/Office: RA/RDP
IRB1090
AXIS 2

Status: Approved	Plant: = Location: + Sublocation: +
Document no. 3HAC085352-007	Rev. Ind 00
	Page 18 Next 19 Total 17

We reserve all rights in this document. No part of this document may be reproduced, stored in a retrieval system, or transmitted in any form or by any means, electronic, mechanical, photocopying, recording, or by any information storage and retrieval system, without express written permission from ABB. © Copyright 2002 ABB

Manipulator Base

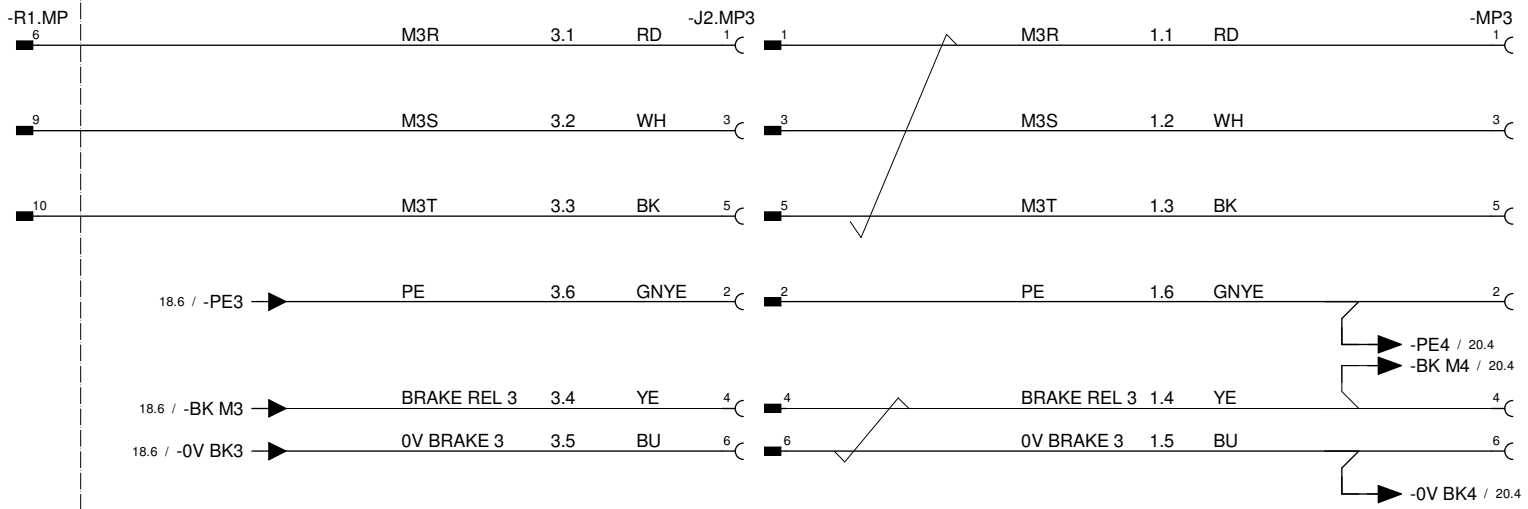

-M3

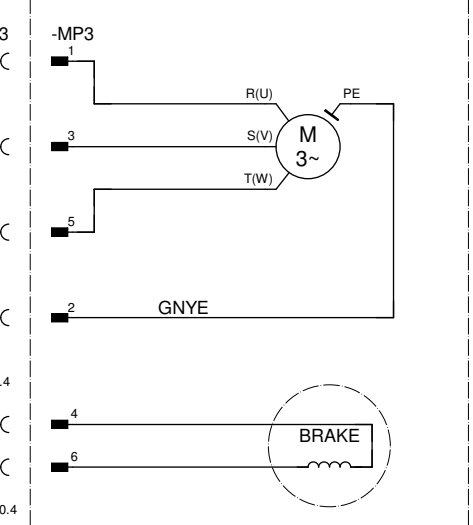

-SMB

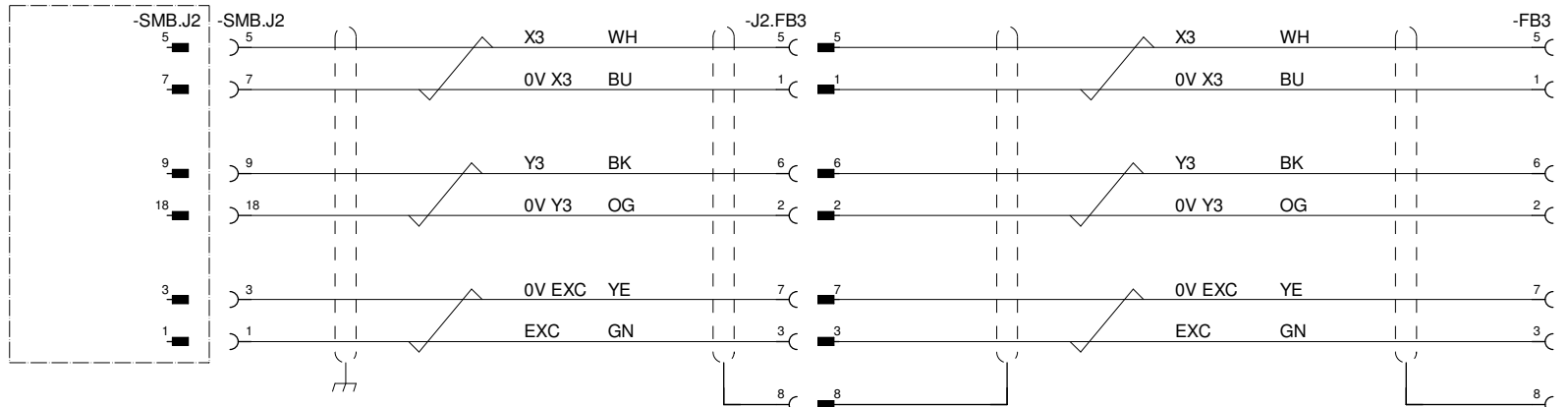

-FB3

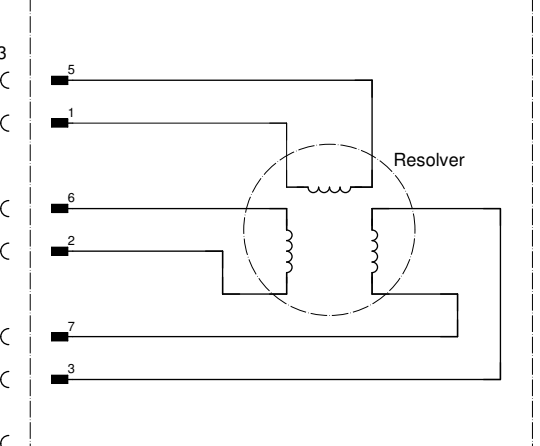

Latest revision:
Prepared by, date: CNPAXU1 | Approved by, date: CNKEWAN10



Lab/Office: RA/RDP
IRB1090
AXIS 3

Status: Approved
Plant: =
Location: +
Sublocation: +
Document no. 3HAC085352-007
Rev. Ind 00
Page 19
Next 20
Total 17

We reserve all rights in this document. No part of this document may be reproduced, stored in a retrieval system, or transmitted in any form or by any means, electronic, mechanical, photocopying, recording, or by any information storage and retrieval system, without express written permission from ABB. © Copyright 2002 ABB

We reserve all rights in this document. No part of this document may be reproduced, stored in a retrieval system, or transmitted in any form or by any means, electronic, mechanical, photocopying, recording, or by any information storage and retrieval system, without express written permission from ABB. © Copyright 2002 ABB

Manipulator Base

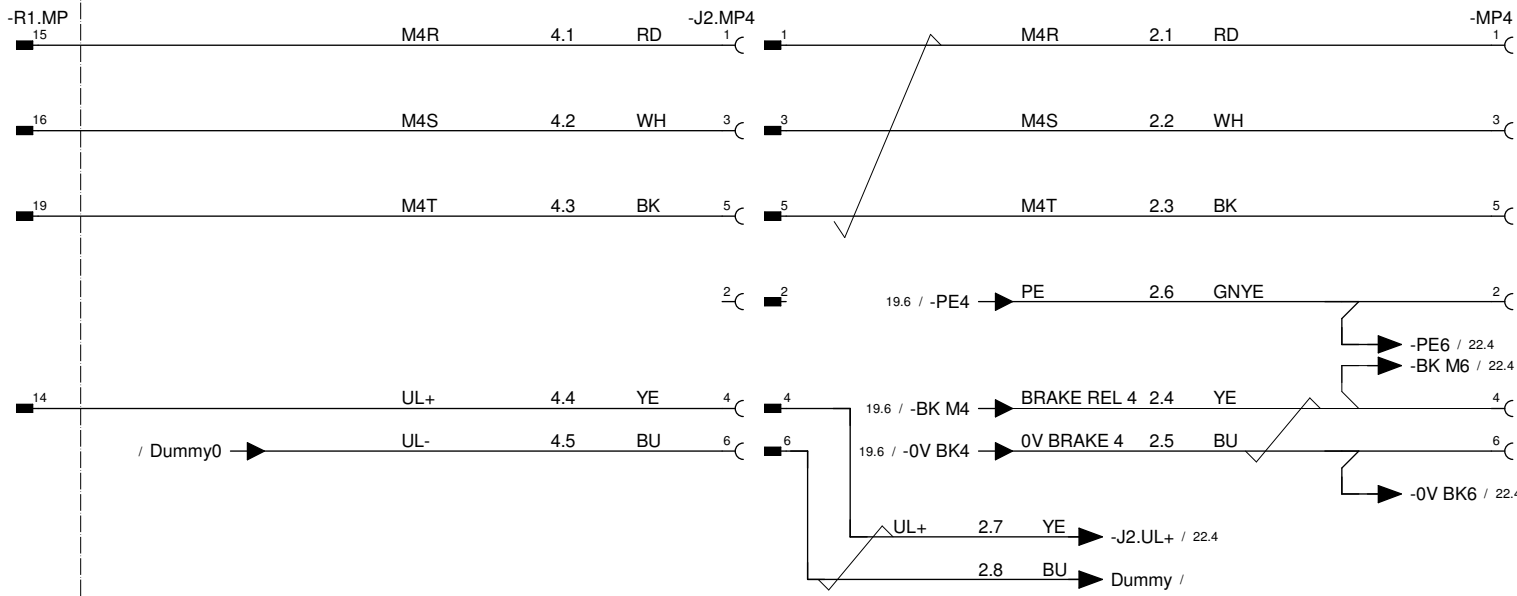

-M4

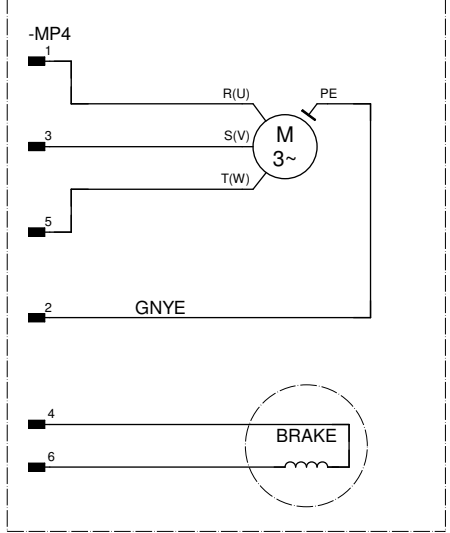

-SMB

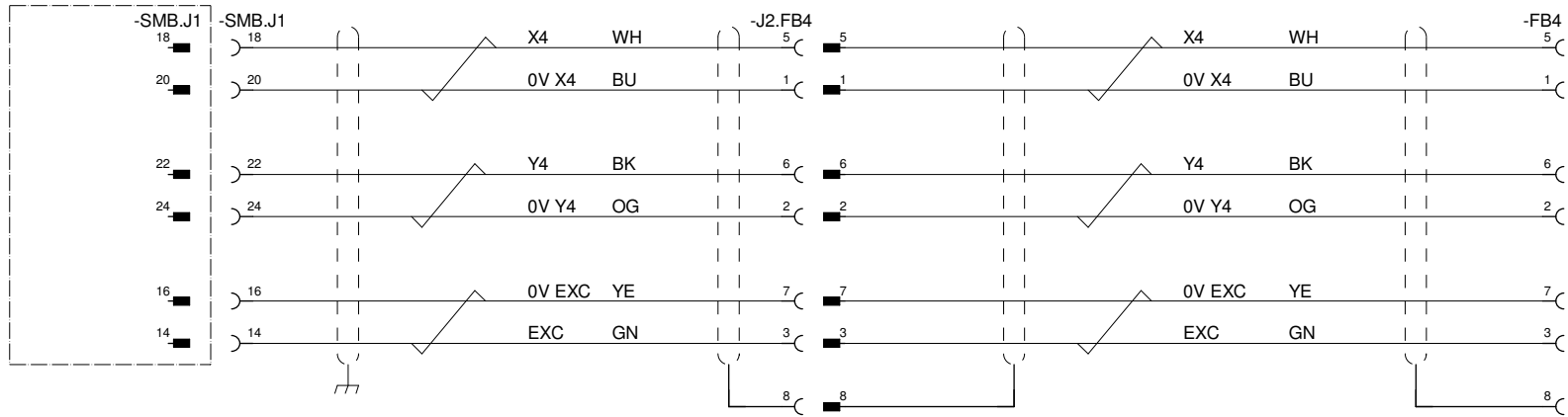

-FB4

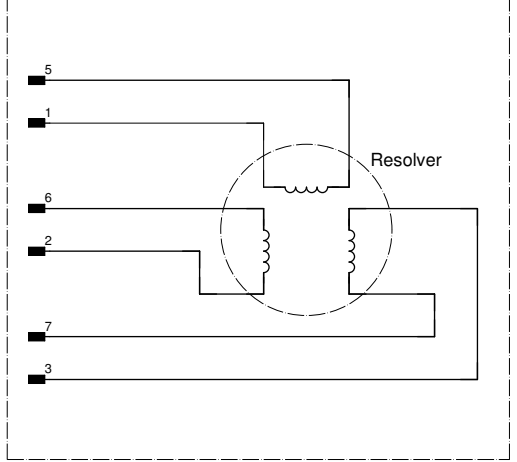

Latest revision: _____
 Prepared by, date: CNPAXU1 Approved by, date: CNKEWAN10

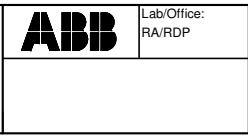

IRB1090
 AXIS 4

Status: Approved	Plant: = Location: + Sublocation: +
Document no. 3HAC085352-007	Rev. Ind 00
	Page 20 Next 21 Total 17

We reserve all rights in this document. No part of this document may be reproduced, stored in a retrieval system, or transmitted in any form or by any means, electronic, mechanical, photocopying, recording, or by any information storage and retrieval system, without express written permission from ABB. © Copyright 2002 ABB

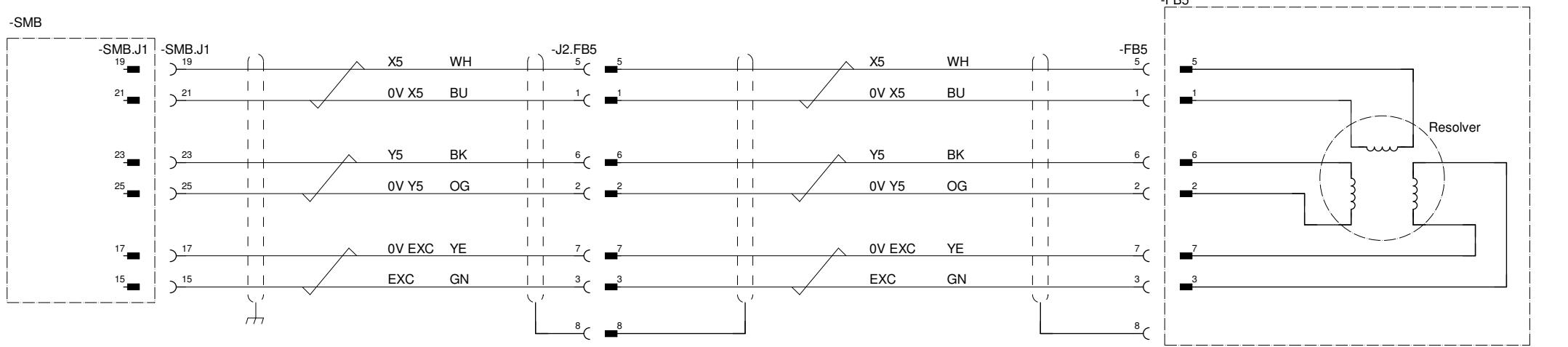
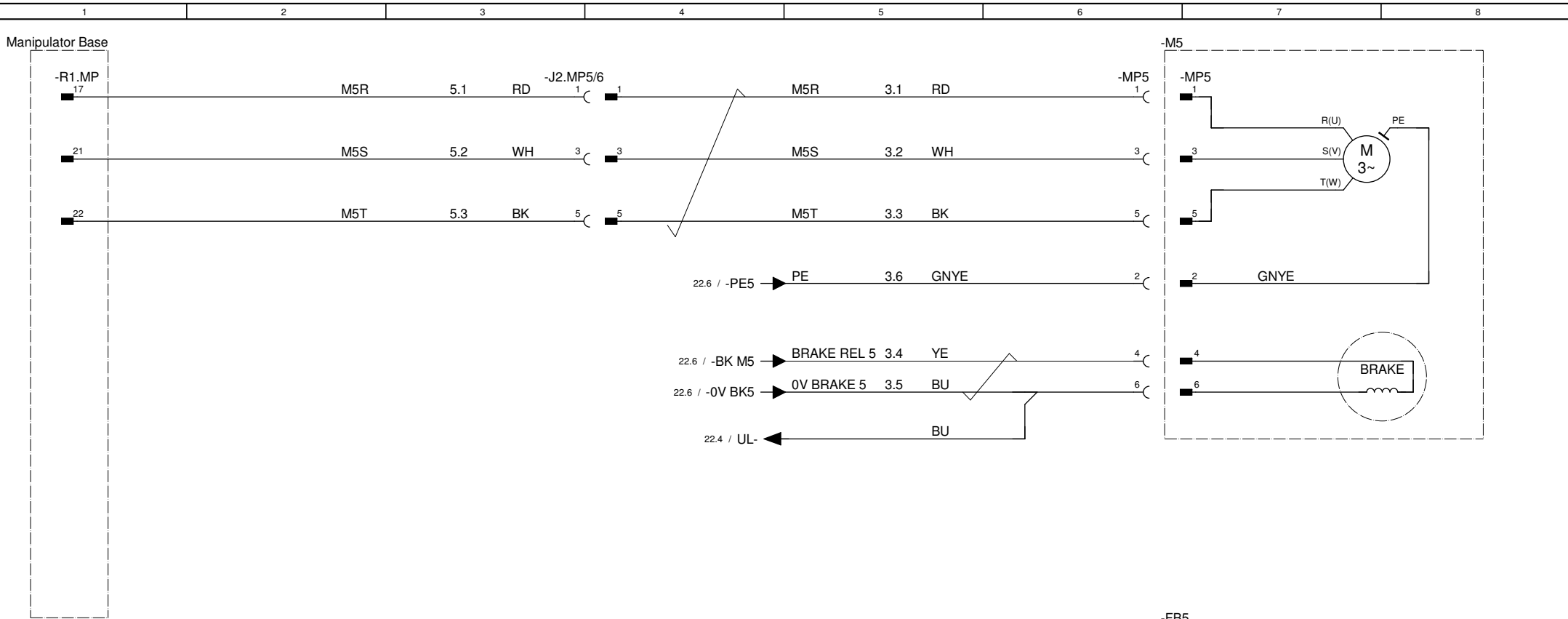

Latest revision:

Prepared by, date: CNPAXU1 | Approved by, date: CNKEWAN10

ABB Lab/Office: RA/RDP

IRB1090
AXIS 5

Status: Approved	Plant: = Location: + Sublocation: +
Document no. 3HAC085352-007	Rev. Ind 00
	Page 21 Next 22 Total 17

We reserve all rights in this document. No part of this document may be reproduced, stored in a retrieval system, or transmitted in any form or by any means, electronic, mechanical, photocopying, recording, or by any information storage and retrieval system, without express written permission from ABB. © Copyright 2002 ABB

Manipulator Base

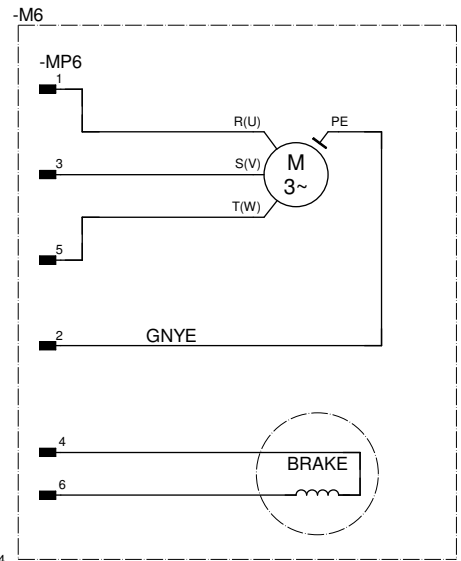
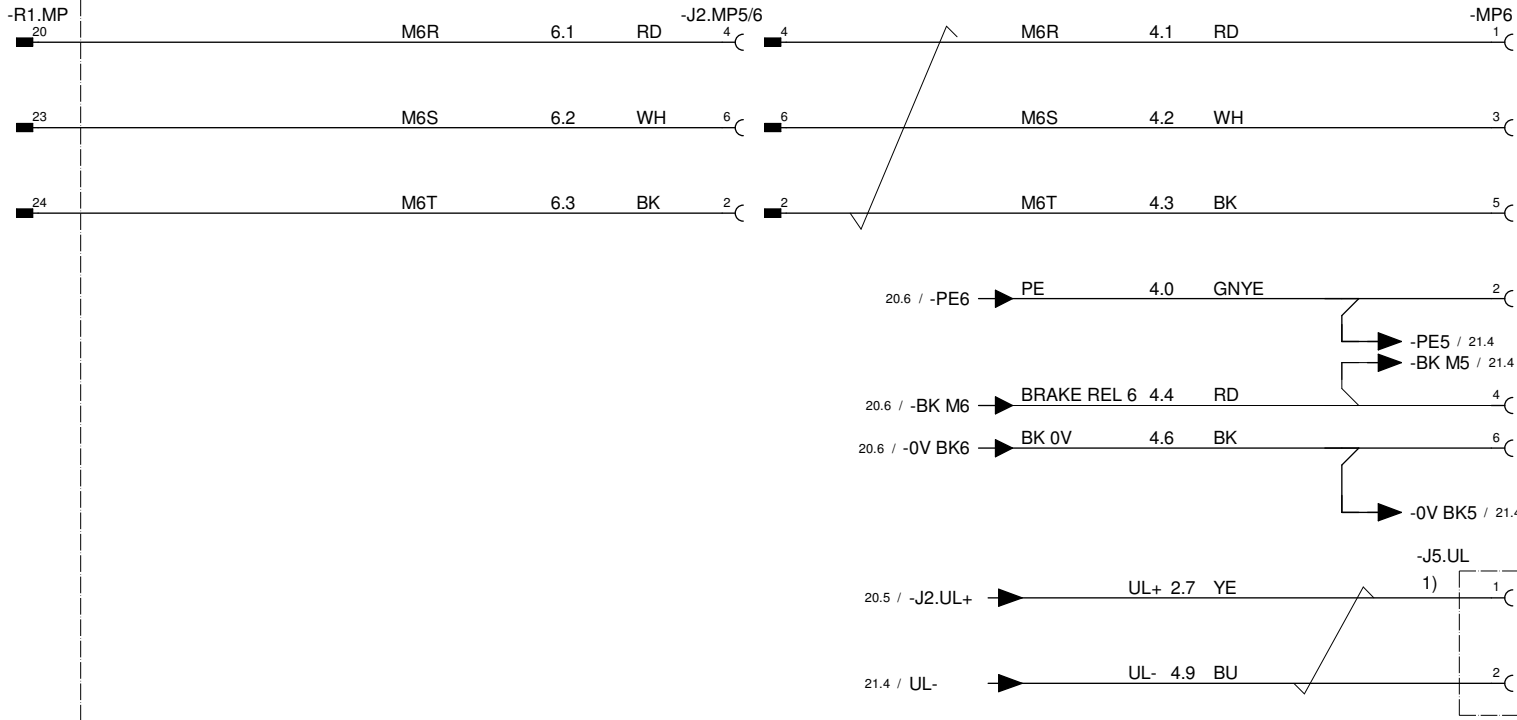

1) J5.UL is only reserved for UL lamp.

-SMB

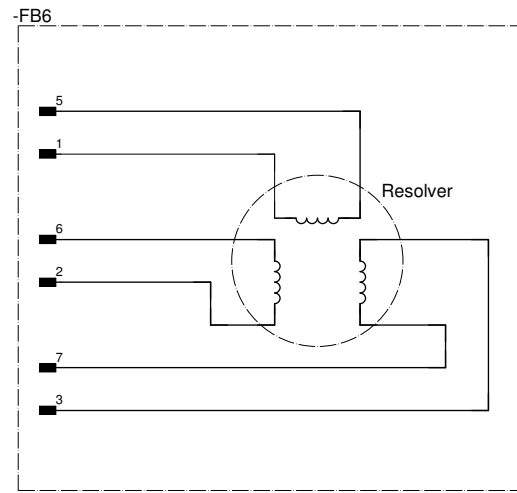
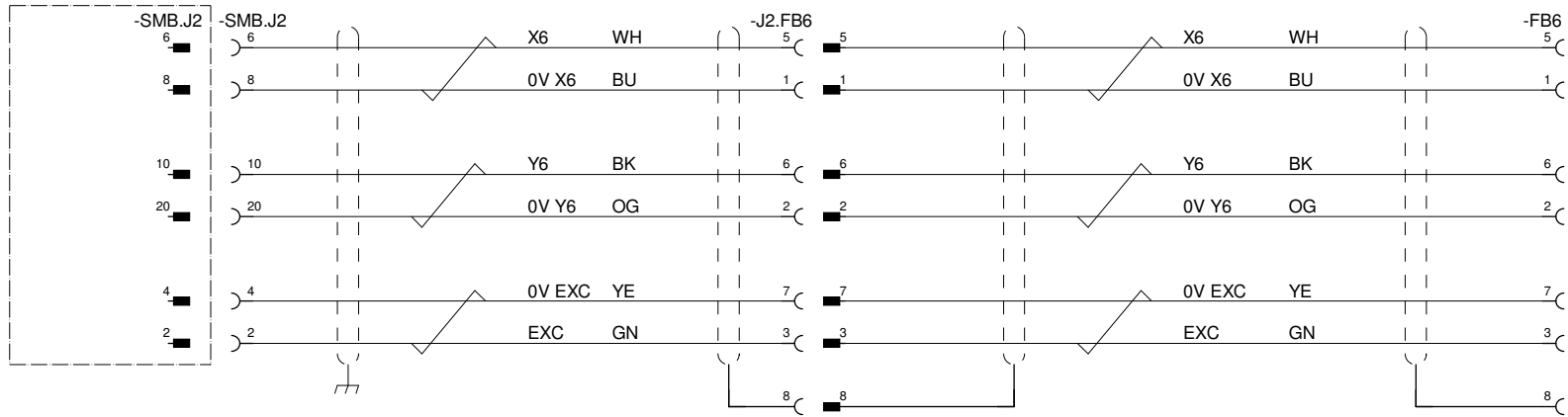

Latest revision: _____

Prepared by, date: CNPAXU1 | Approved by, date: CNKEWAN10

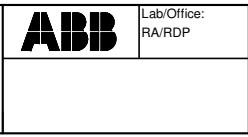

Lab/Office: RA/RDP
 IRB1090
 AXIS 6

Status: Approved	Plant: = Location: + Sublocation: +
Document no. 3HAC085352-007	Rev. Ind 00
	Page 22 Next 23 Total 17

Free end wire

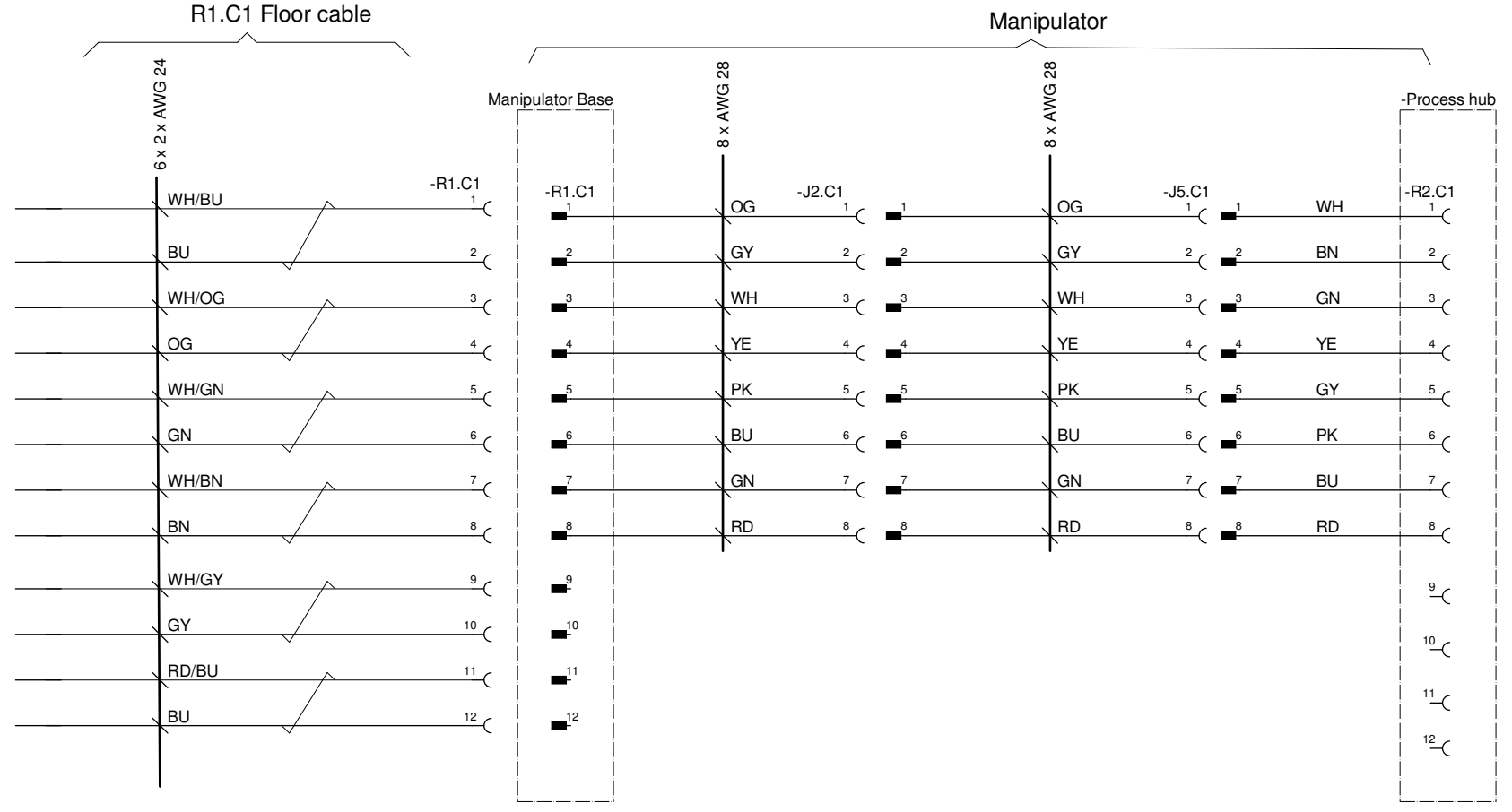

Note : 1) Maximum rating in each C1 wire: 30V, 1.5A. Stresses above the limitation may cause permanent damage to the manipulator.

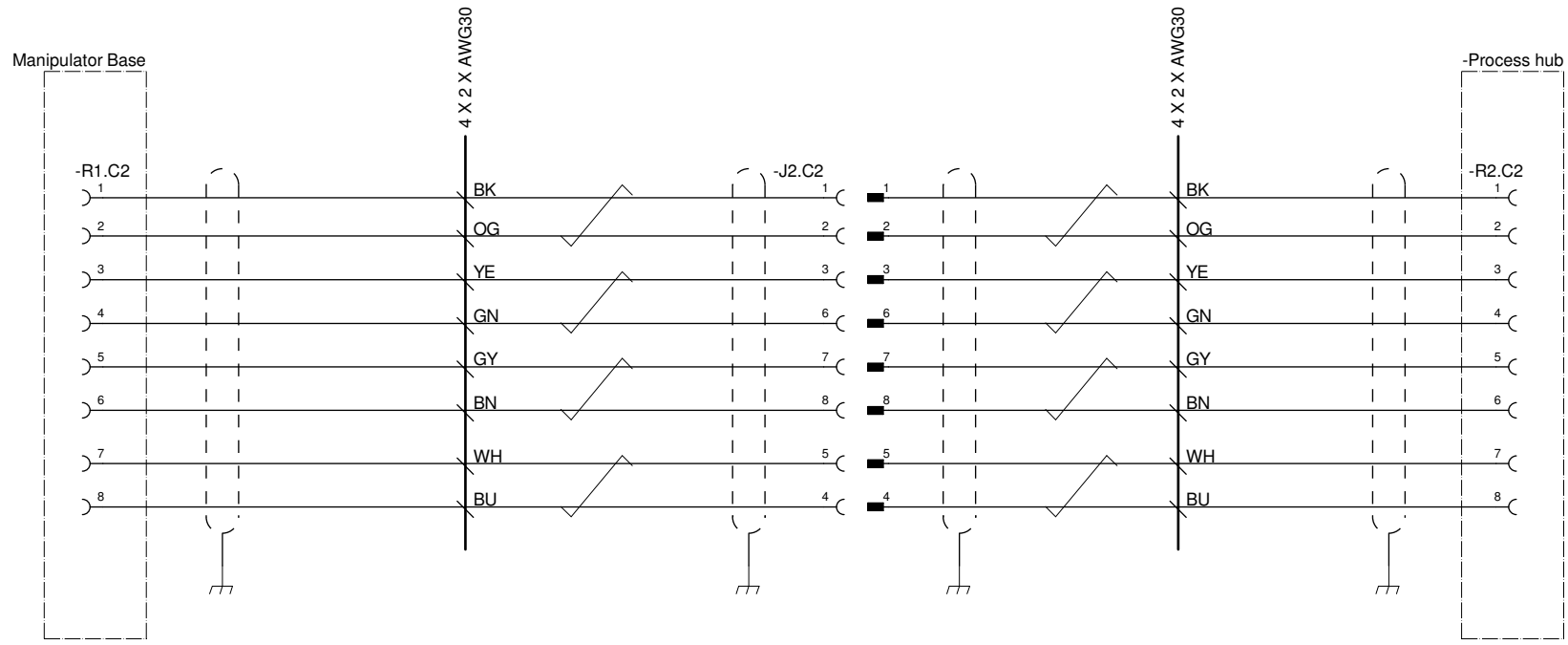

Note : 1): Ethernet cable connecting instruction 3HAC063936-005
 2): Maximum rating in each C2 wire: 30V, 1A (when not using for Ethernet). Stresses above the limitation may cause permanent damage to the manipulator.

we reserve all rights in this document. No part of this document may be reproduced, stored in a retrieval system, or transmitted in any form or by any means, electronic, mechanical, photocopying, recording, or by any information storage and retrieval system, without express authority in writing from ABB. © Copyright 2002 ABB